

MODEL SJ-300F RESILIENT SEATED BUTTERFLY VALVE

The Model SJ-300F Butterfly Valve is a grooved-end shut-off valve equipped with a weatherproof worm gear operator and supervisory switch and wiring.

The Model SJ-300F is cULus and FM approved for 300 psi (20 Bar, 2.0 MPa) WWP (water working pressure) service for indoor and outdoor use[^]. Flow characteristics satisfy UL Specification 1091 and FM Approval Standard 1112.

When the Model SJ-300F Butterfly Valve is used in a fire protection pipeline, installation shall conform to NFPA 13 and NFPA 72.

The valve consists of an epoxy powder coated ductile iron body and EPDM rubber encapsulated dual-seal disc.



For Fire Protection pressure rating, listing, and approval information, refer to Data Sheet B-42 or visit **SHURJOINT** website, www.shurjoint.com for details or contact your **SHURJOINT** Representative.

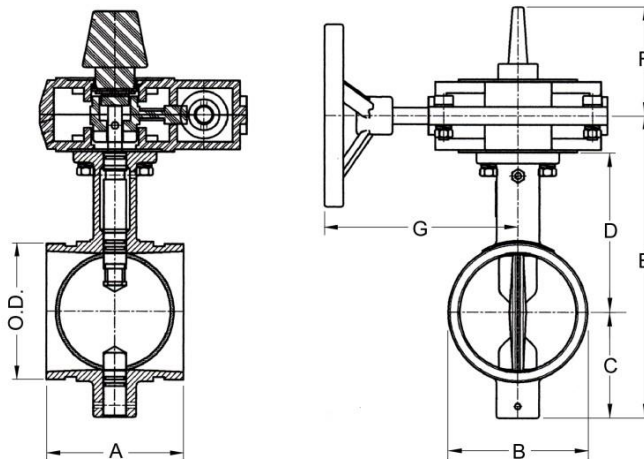

Model SJ-300F Resilient Seated Butterfly Valve										
Nominal Size	Pipe O.D.	Working Pressure (CWP)*	Dimensions							Weight ⁽²⁾
			A ⁽¹⁾	B	C	D	E	F	G	
in mm	in mm	PSI Bar	in mm	in mm	in mm	in mm	in mm	in mm	in mm	Lbs Kgs
2 50	2.375 60.3	300 20	3.19 81	2.56 65	2.48 63	4.17 106	7.87 200	3.62 92	6.42 163	16.70 7.60
2½ 65	2.875 73.0	300 20	3.81 97	3.15 80	2.68 68	4.37 111	8.27 210	3.62 92	6.42 163	18.26 8.30
76.1 mm	3.000 76.1	300 20	3.81 97	3.15 80	2.68 68	4.37 111	8.27 210	3.62 92	6.42 163	18.41 8.37
3 80	3.500 88.9	300 20	3.81 97	3.62 92	3.00 76	4.96 126	9.17 233	3.62 92	6.42 163	18.92 8.60
4 100	4.500 114.3	300 20	4.56 116	4.65 118	3.50 89	5.31 135	10.04 255	3.62 92	6.42 163	21.78 9.90
139.7 mm	5.500 139.7	300 20	5.81 148	5.71 145	4.00 102	6.61 168	11.85 301	3.62 92	6.42 163	27.08 12.31
5 125	5.500 141.3	300 20	5.81 148	5.71 145	4.00 102	6.61 168	11.85 301	3.62 92	6.42 163	26.84 12.20

Model SJ-300F Resilient Seated Butterfly Valve										
Nominal Size	Pipe O.D.	Working Pressure (CWP)*	Dimensions							Weight ⁽²⁾
			A ⁽¹⁾	B	C	D	E	F	G	
in mm	in mm	PSI Bar	in mm	in mm	in mm	in mm	in mm	in mm	in mm	Lbs Kgs
165.1 mm	6.500 165.1	300 20	5.81 148	6.77 172	4.50 114	7.25 184	12.95 329	3.62 92	6.42 163	30.38 13.81
6 150	6.625 168.3	300 20	5.81 148	6.77 172	4.50 114	7.25 184	12.95 329	3.62 92	6.42 163	30.14 13.70
8 200	8.625 219.1	300 20	5.24 133	8.74 222	5.51 140	8.19 208	14.92 379	3.62 92	6.42 163	38.72 17.60
200 JIS	8.516 216.3	300 20	5.24 133	8.74 222	5.51 140	8.19 208	14.92 379	3.62 92	6.42 163	38.72 17.60
10 250	10.750 273.0	300 20	6.25 159	10.87 276	6.69 170	9.25 235	17.17 436	3.62 92	6.42 163	59.27 26.88
12 300	12.750 323.9	300 20	6.50 165	12.87 327	8.07 205	10.24 260	19.53 496	3.62 92	6.42 163	74.97 34.00

(1) End to end dimensions conforms to MSS SP-67.

(2) The weight includes the worm gear operator.

*Working pressure is based on connection with roll- or cut-grooved standard wall carbon steel pipe.

(^) Please check approvals section at www.shurjoint.com/eng/approvals.aspx for sizes that are UL listed and FM approved

Valve Torque Requirements

These torque values were derived from test data with non-lubricated valves in water, non-pressurized at ambient temperatures with EPDM seals.

Model SJ-300F Butterfly Valve Torque Requirements		
Nominal Size	Pipe O.D.	Torque
in mm	in mm	Lbs-in Nm
2 50	2.375 60.3	80 9
2½ 65	2.875 73.0	120 14
76.1 mm	3.000 76.1	120 14
3 80	3.500 88.9	160 18
4 100	4.500 114.3	450 51
139.7 mm	5.500 139.7	700 79
5 125	5.563 141.3	700 79
165.1 mm	6.500 165.1	900 102
6 150	6.625 168.3	900 101.7
8 200	8.625 219.1	1200 136
200 JIS	8.516 216.3	1200 136
10 250	10.750 273.0	1800 203
12 300	12.750 323.9	2500 283

Note: The torque values are based on liquid applications. For dry or non-lubricating applications add a 25% service factor to the above values.

Flow Data – C_v Values

C_v values for flow of water at +60°F (+16°C) with a fully open valve are shown in the table below.
For additional details, contact **Shurjoint**.

Formula for C_v Values:

$$C_v = \frac{Q}{\sqrt{\Delta P}}$$

Where: C_v = Flow coefficient
Q = Flow (GPM)
ΔP = Pressure drop (psi)

Model #SJ-300F C _v (Fully Open)		
Nominal Size (in)	Equivalent Length on Sch. 40 pipe* Feet (Meter)	C _v Values
2	4.7 (1.4)	120
2½	5.2 (1.6)	210
3	5.5 (1.7)	380
4	6.8 (2.1)	720
5	8.5 (2.6)	1150
6	7.4 (2.3)	2000
8	9.2 (2.8)	3800
10	13.5 (4.1)	5500
12	15.1 (4.6)	8250

This chart should be used as a general guide.
*At 15 feet/sec, (4.6m/s) Velocity of water

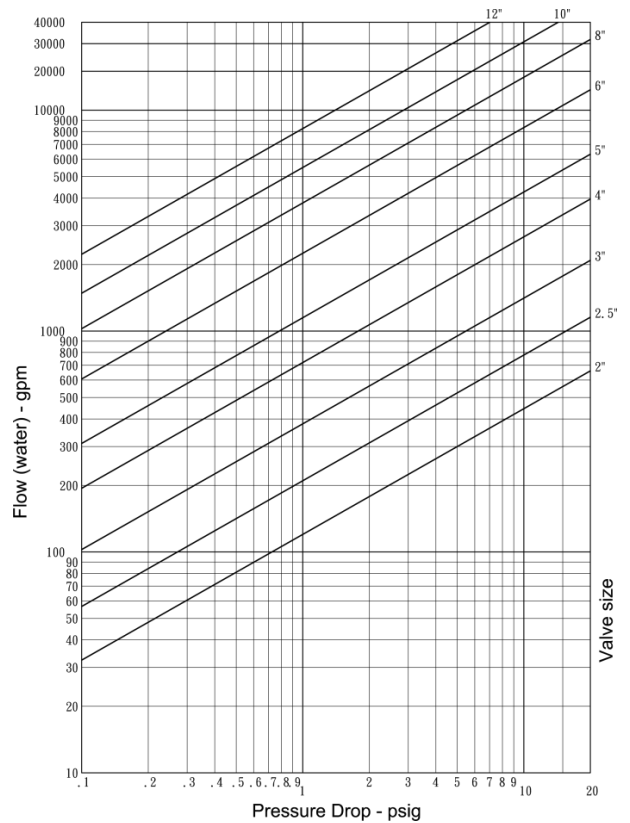

Switch & Wiring

The supervisory switch is designed to supervise in the “open” position and contains two, single pole, double throw, pre-wired switches.

Switch 1 (S1) has two #18 AWG wires per terminal used for connection to supervisory circuit of a UL listed alarm control panel.

Normally closed: (2) Blue
Common: (2) Yellow

Switch 2 (S2) has one #18 AWG wire per terminal for connection to auxiliary devices which may be required by the authority having jurisdiction.

Normally closed: (1) Red
Normally open: (1) Black
Common: (1) White

This double circuit provides flexibility to operate two electrical devices at separate locations, such as an indicating light and an audible alarm, in the area that the valve is installed.

Besides, a #14 AWG ground lead (green) is provided.

The diagram shows a typical connection between the common terminal and the normally closed terminal. The indicator light and alarm will stay on until the valve is fully open. When the valve is fully open, the indicator light and alarm will go out.

The connection of the alarm switch wiring shall be in accordance with NFPA 72 and the auxiliary switch per NFPA 70 (NEC).

SWITCH WIRING DIAGRAM

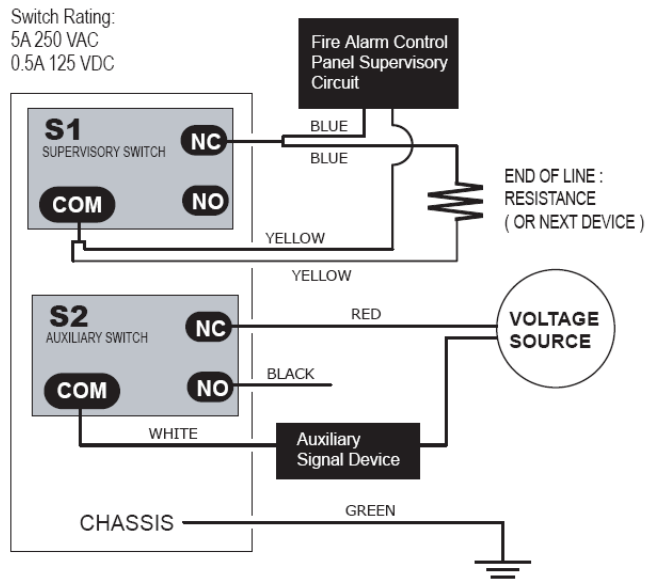

MATERIAL SPECIFICATIONS

- **Valve Body & Disc:**

Ductile Iron to ASTM A536, Gr. 65-45-12 and or to ASTM A395, Gr. 65-45-15, min. tensile strength 65,000 psi (448 MPa).

- **Valve Body Coating:**

Epoxy powder coating, black color.

- **Disc Encapsulation:**

Grade E-pw EPDM (Color code: Double Green stripe) Good for potable water service to +180°F (+82°C). Also good for services for water with acid, water with chlorine, deionized water, seawater and waste water, dilute acids, oil-free air and many chemicals.

Not recommended for petroleum oils, minerals oils, solvents and aromatic hydrocarbons.

- **Grade “E” EPDM** (Color code: Green stripe) Good for cold & hot water up to +230°F (+110°C). Also good for services for water with acid, water with chlorine, deionized water, seawater and waste water, dilute acids, oil-free air and many chemicals.

Not recommended for petroleum oils, minerals oils, solvents and aromatic hydrocarbons.

Maximum Temperature Range: -30°F (-34°C) to +230°F (+110°C)*.

*EPDM seat for water services are not recommended for steam services unless valves or components are accessible for frequent replacement.

- **Upper & Lower Shafts:**

Stainless steel Type 410.

- **Shaft Bearing:**

Teflon.

- **Stem Seals:**

O-Ring, Nitrile.

General Notes:

- **Maximum Working Pressure (CWP)** listed is the maximum cold water pressure for general piping services tested to ASTM F1476 and or AWWA C606 methods. Figures listed are based on roll- or cut-grooved standard wall carbon steel pipe. For other pipe schedules or pipe materials, contact **Shurjoint** for additional information.
- **Listed and or Approved Pressures** are pressure ratings for fire protection systems, tested and approved by various approval bodies. Please always refer to the latest approval data posted on the **Shurjoint** website.
- **Field Joint Test:** For one time only the system may be tested hydrostatically at 1½ times the maximum working pressure listed (AWWA C606 5.2.3).
- **Warning:** Piping systems must always be depressurized and drained before attempting disassembly and or removal of any components.
- **The Limited Warranty** applies to manufacturing defects only and does not cover severe service/temperature applications or wear parts.
- **Shurjoint** reserves the right to change specifications, designs and or standard without notice and without incurring any obligations.

Job Name:	System No.	Location:	
Contractor:	Approved:	Date:	
Engineer:	Approved:	Date:	

Shurjoint product specifications in U.S. customary units and metric are approximate and are provided for reference only. For precise measurements, please contact **Shurjoint** Technical Service. **Shurjoint** reserves the right to change or modify product design, construction, specifications, or materials without prior notice and without incurring any obligations to make such changes and modifications on **Shurjoint** products previously subsequently sold.