

MODEL SJ-530 THREE PORT BALL VALVE

The **Shurjoint** Model SJ-530 is a grooved-end three-port ball valve designed to divert media from bottom inlet to either of the two outlets ports. The valve port is a regular port size and the stem is a blowout proof design to MSS SP-72 and API Standard 608. The valve is supplied with a carbon steel lever handle equipped with a tamper resistant locking device.

The valve body is made of ferritic ductile iron conforming to ASTM A395/A (UNS F33100) with black electro deposition coating. The three-port ball is austenitic stainless steel to ASTM A351 CF8M (316) and blowout proof stem is stainless steel to ASTM A479 Type 316. All materials are chosen to meet the requirements of NACE MR0175-2003.

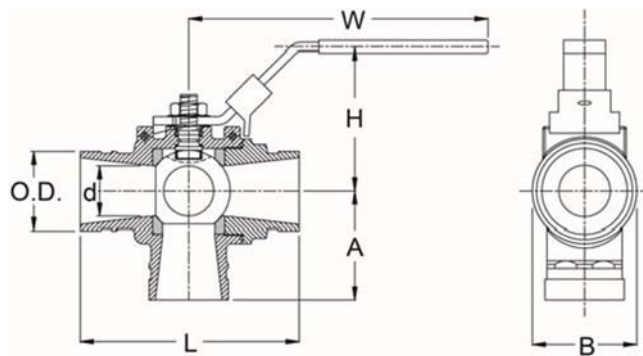

Model SJ-530 Three Port Ball Valve

Nominal Size	Pipe O.D.	Working Pressure (CWP)*	Operating		Dimensions					Weight
			Torque‡		L	H	W	A	B	
in mm	in mm	PSI Bar	Lbs-in Nm	in mm	in mm	in mm	in mm	in mm	in mm	Lbs Kgs
2	2.375	600	150	6.55	4.32	8.96	1.50	3.25	3.13	7.89
50	60.3	42	17	167	110	228	38	83	79	3.58

* Working pressure is based on connection with roll- or cut-grooved standard wall carbon steel pipe.

‡ For the first opening or closing of the valve when the valve is not continuously operated, an additional torque of 2.0 – 2.5 times the listed operating torque is normally required.

Flow Characteristics

Valve Size in	C _v / K _v Full Open
2"	36 / 31

MATERIAL SPECIFICATIONS

- **Body and End Cap:**
Ferritic ductile iron to ASTM A395/A (UNS F33100).
- **Surface Finish:**
Black electro-deposition coating.
- **Ball:**
Austenitic stainless steel to ASTM A351 CF8M (316).
- **Stem:**
Austenitic stainless steel to ASTM A479 Type 316.
- **Seats:**
Reinforced PTFE (polytetrafluoroethylene).
- **Body Seal:**
PTFE (polytetrafluoroethylene).
- **Stem Hardware:**
Type 304 Stainless Steel.
- **Lever Handle:**
Carbon steel with plastic grip
 Type 304 stainless steel

General Notes:

- **Maximum Working Pressure (CWP)** listed is the maximum cold water pressure for general piping services tested to ASTM F1476 and or AWWA C606 methods. Figures listed are based on roll- or cut-grooved standard wall carbon steel pipe. For other pipe schedules or pipe materials, contact **Shurjoint** for additional information.
- **Field Joint Test:** For one time only the system may be tested hydrostatically at 1½ times the maximum working pressure listed (AWWA C606 5.2.3).
- **Warning:** Piping systems must always be depressurized and drained before attempting disassembly and or removal of any components.
- **The 10 Year Limited Warranty** applies to manufacturing defects only and does not cover severe service/temperature applications or wear parts.
- **Shurjoint** reserves the right to change specifications, designs and or standard without notice and without incurring any obligations.

Shurjoint product specifications in U.S. customary units and metric are approximate and are provided for reference only. For precise measurements, please contact **Shurjoint** Technical Service. **Shurjoint** reserves the right to change or modify product design, construction, specifications, or materials without prior notice and without incurring any obligations to make such changes and modifications on **Shurjoint** products previously subsequently sold.